

L4TR STRADEASY®

À RADIER À RECONSTITUER

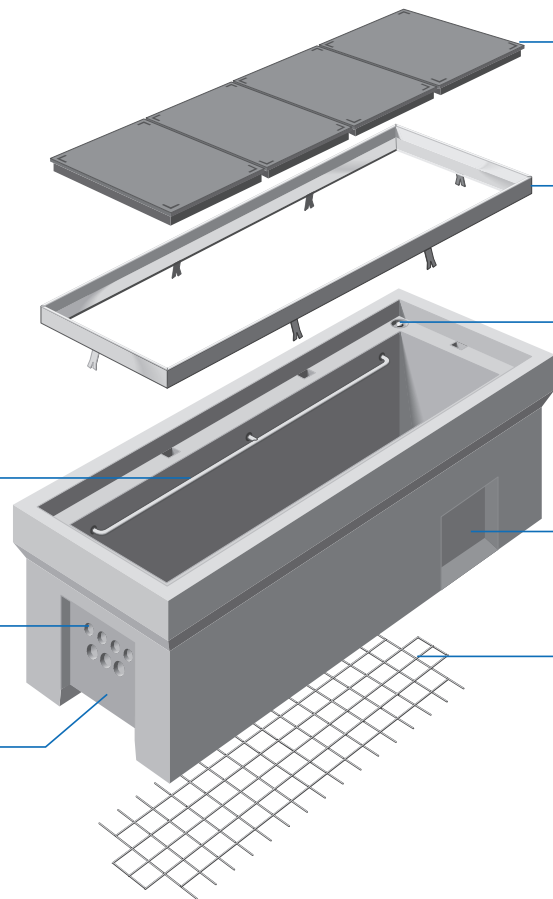

C 250



4 tampons*
633 x 495 mm

Cadre*

Manutention :
ancres de levage

Masque pré-cassable
310 x 200 mm
sur grands piédroits

Armature pour radier
à couler sur chantier

Équipement intérieur :
2 supports équerres

Pré-trous
Ø 45 mm et Ø 60 mm
selon usines de fabrication

Masque pré-cassable
390 x 350 mm
sur petits piédroits

*Cadres et tampons vendus séparément. Cadre scellé en option.

Type L	
L0T	
L0TR	
L1T	
L1TR	
L2T	
L2TR	
L3T	
L3TR	
1/2L4T	
1/2L4TR	
L4T	
L4TR S	
L5T	
L5TR	
L6T	
L6TR	
Type M	
M2T	
M2TR	
Type P	
P1T	
P1TR	
P2T	
P2TR	

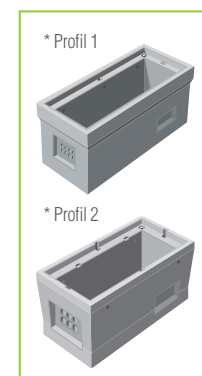
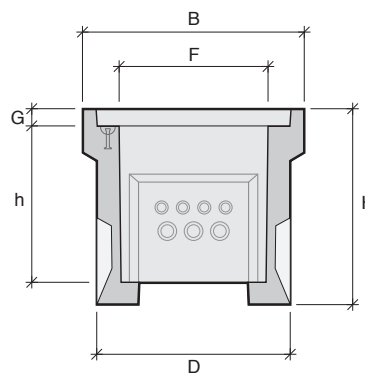
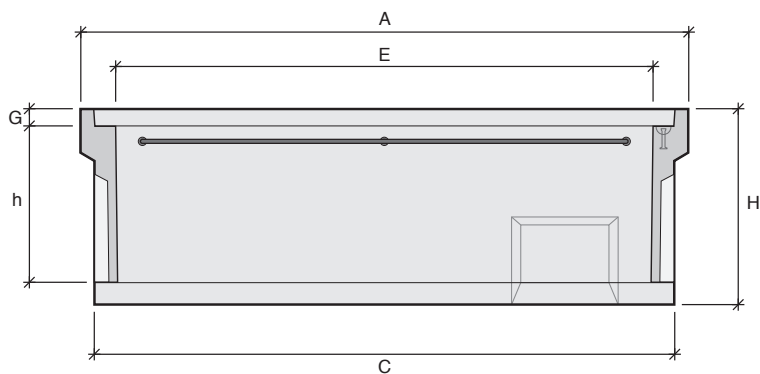

Désignation	Code	Usines	Profils*	A Longueur (mm)	B Largeur (mm)	C Longueur radier (mm)	D Largeur radier (mm)	E Longueur intérieure (mm)	F Largeur intérieure (mm)	H Hauteur totale (mm)	h Hauteur utile (mm)	G Hauteur feuillure (mm)	Poids (kg)	Manutention
L4TR	110025	BI	1	2116	768	2018	670	1870	520	675	540	60	680	2 ancres de 1,3T
		BT	1	2120	773	2003	657	1860	517	687	540	60	680	2 ancres de 1,3T
		EB	1	2122	773	2005	670	1865	515	685	540	60	840	2 ancres de 1,3T
		MX	2	2122	775	2010	660	1876	526	680	540	60	707	2 ancres de 1,3T